

local article number: 447756

ACO Industries k.s.
 Havlíčkova 260
 58222 Příbyslav
 Česká republika
 aco-industries@aco.cz
 www.aco.cz

drawing-no.:
1123338-M
 created by:

index:
001
 reviewed by:

documenttype:
marketing drw.
 projection: ISO-E

 scale:
1:5

title:
Deckline P
Deckline P100 OS channel 1m
Deckline P100 OS žlab 1m

The reproduction, distribution and utilization of this document as well as the communication of its contents to others without express authorization is prohibited. Offenders will be held liable for the payment of damages. All rights reserved in the event of the grant of a patent, utility model or design. Observe copyright by ISO 16016

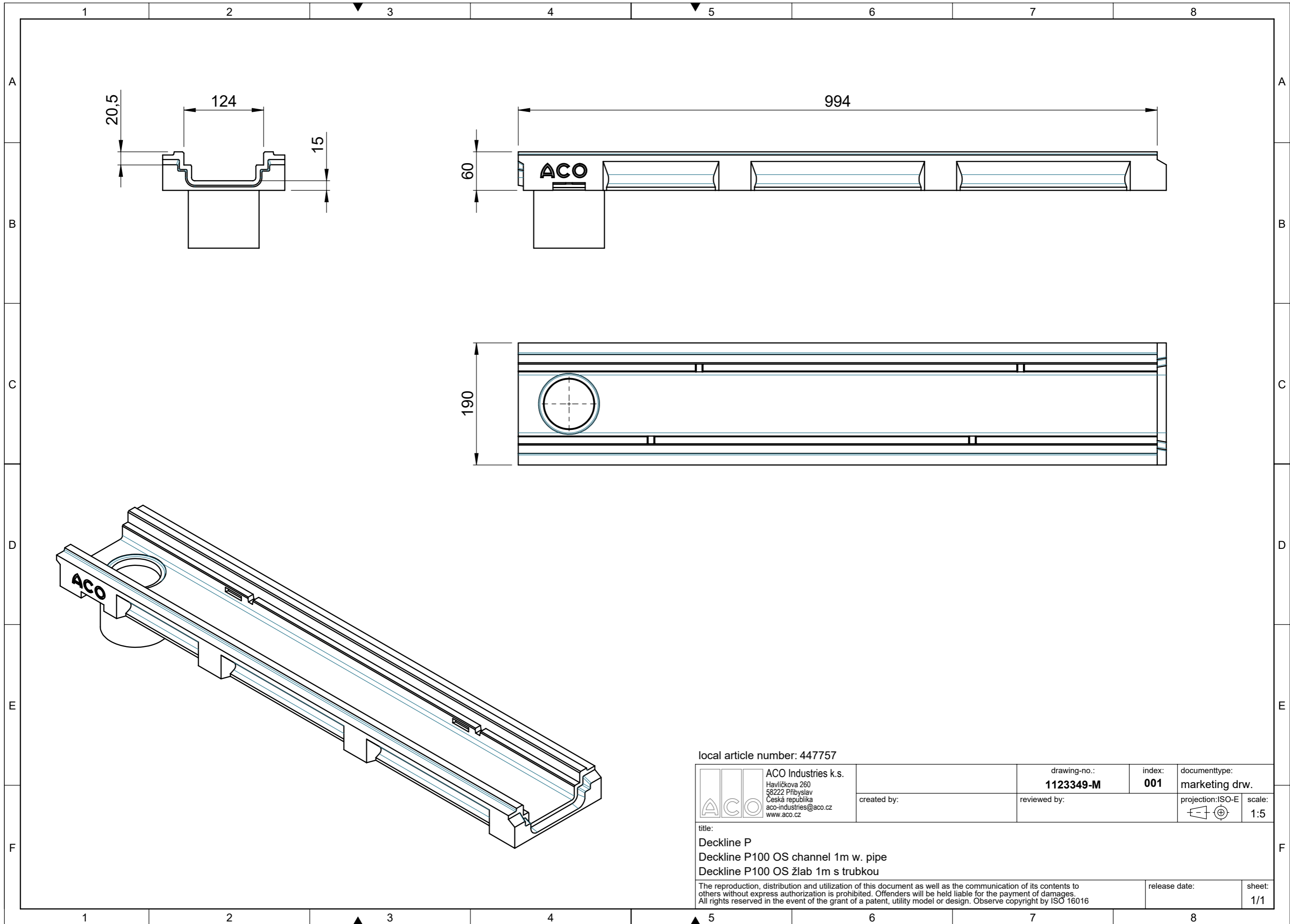
release date: sheet:
1/1



local article number: 447757

	ACO Industries k.s. Havlíčkova 260 58222 Příbyslav Česká republika aco-industries@aco.cz www.aco.cz	drawing-no.: 1123349-M	index: 001	documenttype: marketing drw.
	created by:	reviewed by:	projection: ISO-E 	scale: 1:5

title:
Deckline P
Deckline P100 OS channel 1m w. pipe
Deckline P100 OS žlab 1m s trubkou

The reproduction, distribution and utilization of this document as well as the communication of its contents to others without express authorization is prohibited. Offenders will be held liable for the payment of damages. All rights reserved in the event of the grant of a patent, utility model or design. Observe copyright by ISO 16016

release date: _____ sheet: **1/1**

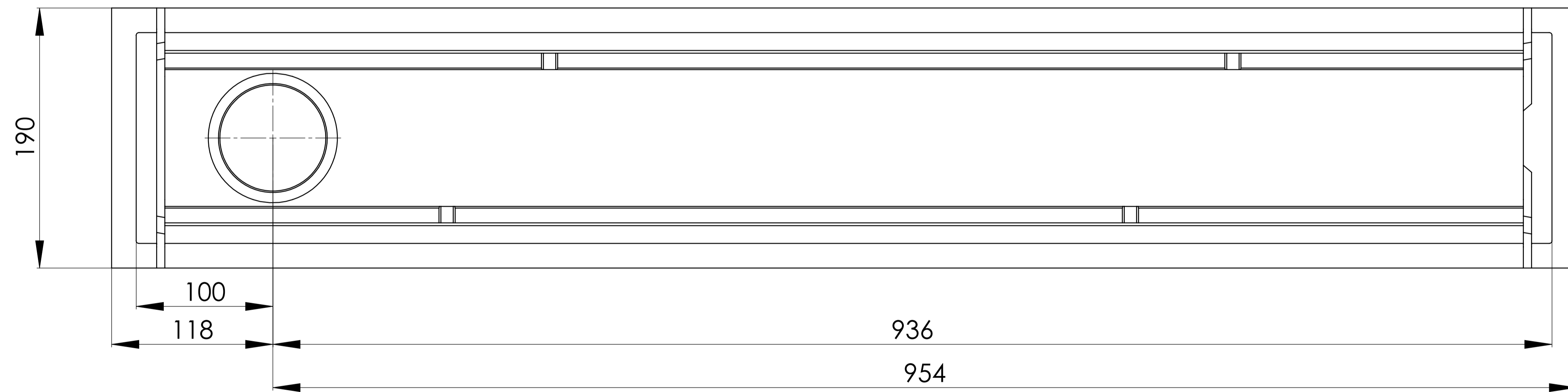
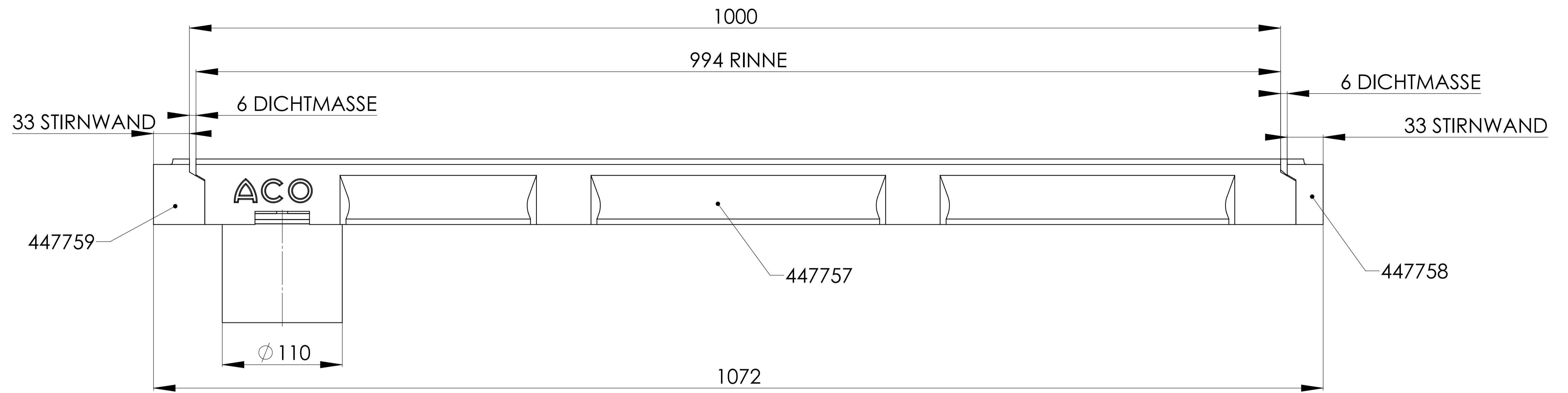

Materiál:		Hmotnost:		ACO Industries k.s.	
ISO 2768-mK		13,26 kg		Havlíkova 260 Tel.: +420 569 491 202 582 22 Pílskýšov Fax: +420 569 482 529	
Tolerovňa:		Početov:		Sestava	
Kreslí:	Datum:	číslo:	Mřížka:	1:2	mm
Kontroloval:	28.4.2021	XXXX			
Titik:	28.4.2021				
Číslo výkresu:				Index	
P1000S				000	
Líst: 1		Líst: 1		Formát: A1	

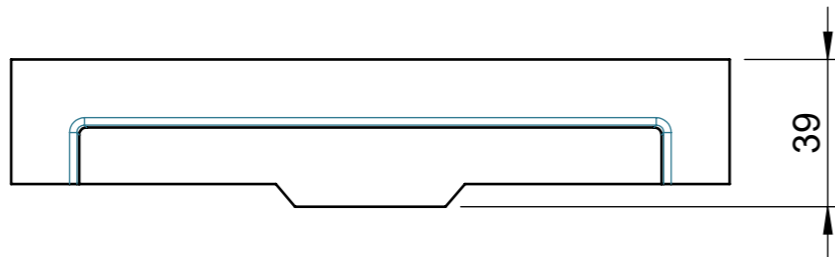
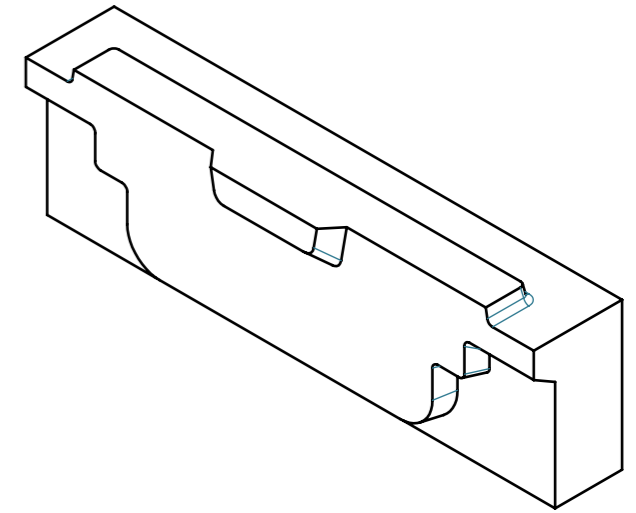
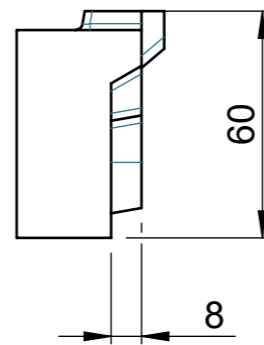
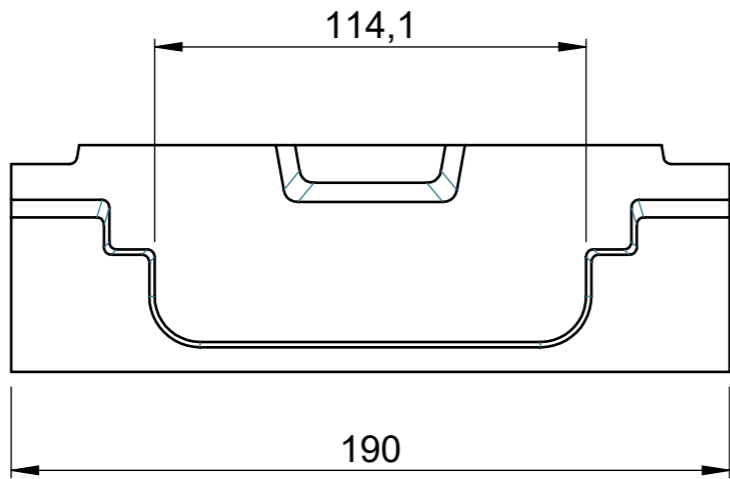
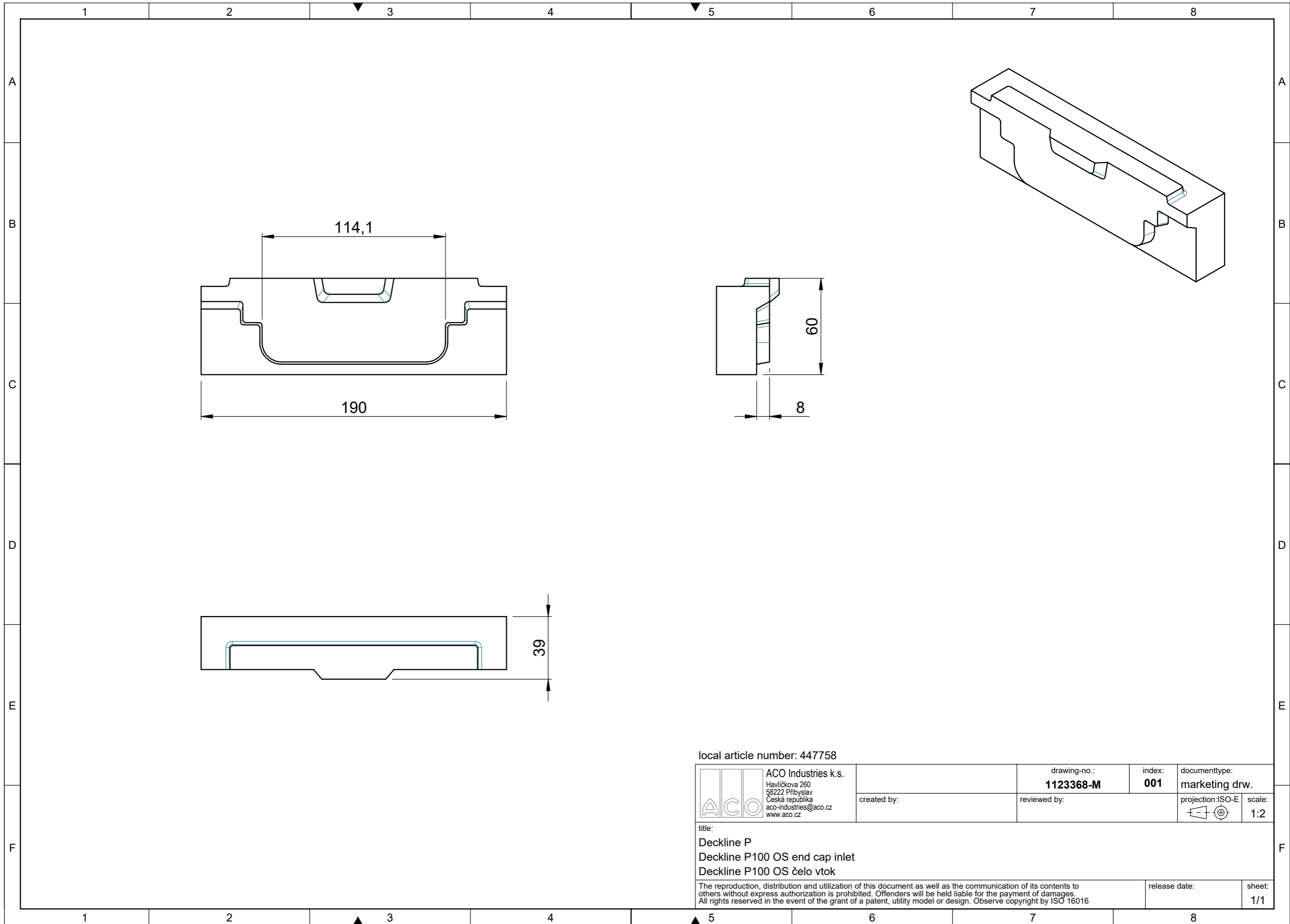

local article number: 447758

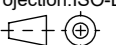
 ACO Industries k.s. Havlíčkova 260 58222 Příbyslav Česká republika aco-industries@aco.cz www.aco.cz	drawing-no.: 1123368-M	index: 001	documenttype: marketing drw.
	created by:	reviewed by:	projection: ISO-E  scale: 1:2
title: Deckline P Deckline P100 OS end cap inlet Deckline P100 OS čelo vtok			release date:
The reproduction, distribution and utilization of this document as well as the communication of its contents to others without express authorization is prohibited. Offenders will be held liable for the payment of damages. All rights reserved in the event of the grant of a patent, utility model or design. Observe copyright by ISO 16016			sheet: 1/1

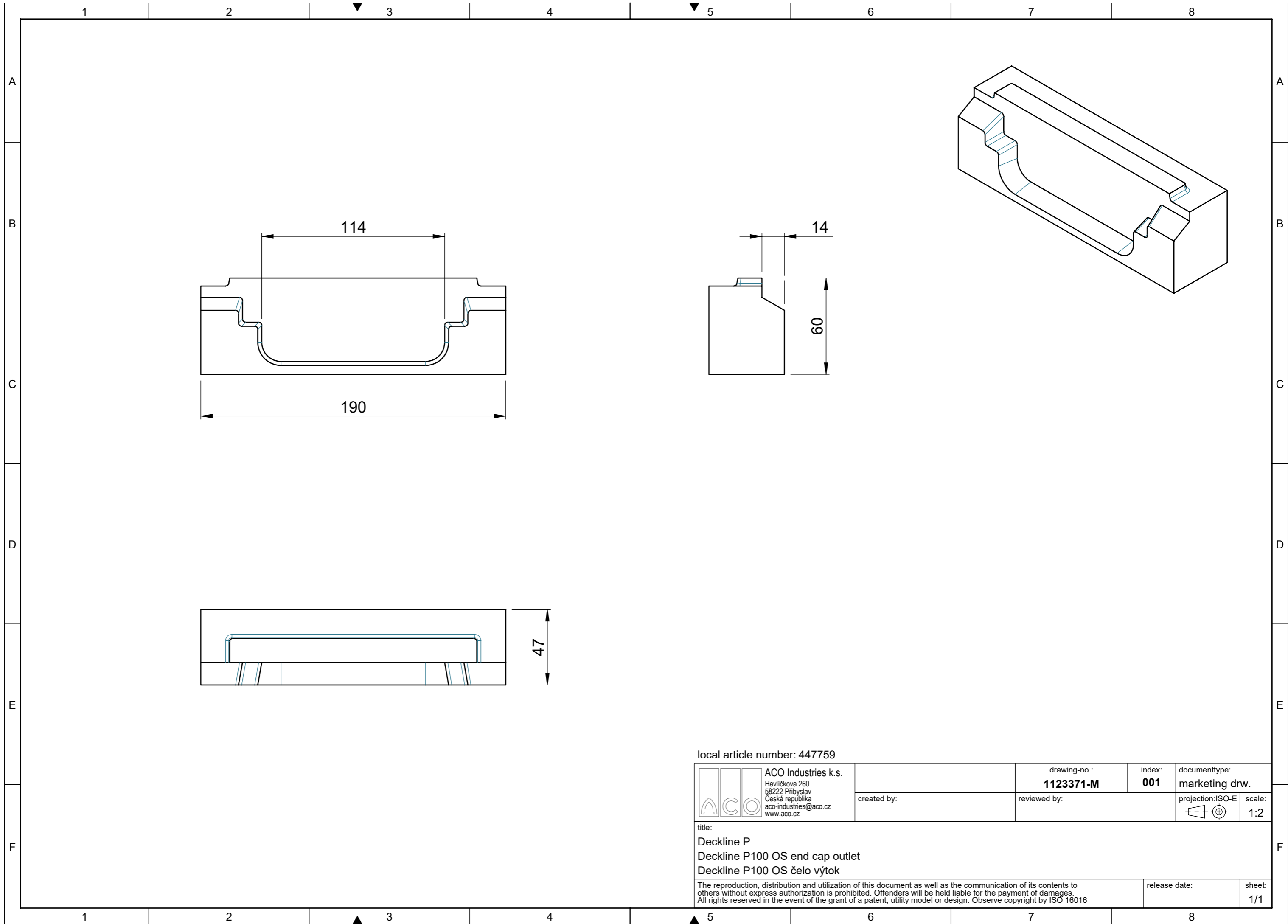

local article number: 447759

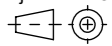
 ACO Industries k.s. Havlíčkova 260 58222 Příbyslav Česká republika aco-industries@aco.cz www.aco.cz	drawing-no.: 1123371-M	index: 001	documenttype: marketing drw.
	created by:	reviewed by:	projection: ISO-E 
title: Deckline P Deckline P100 OS end cap outlet Deckline P100 OS čelo výtok			scale: 1:2
The reproduction, distribution and utilization of this document as well as the communication of its contents to others without express authorization is prohibited. Offenders will be held liable for the payment of damages. All rights reserved in the event of the grant of a patent, utility model or design. Observe copyright by ISO 16016			release date: sheet: 1/1

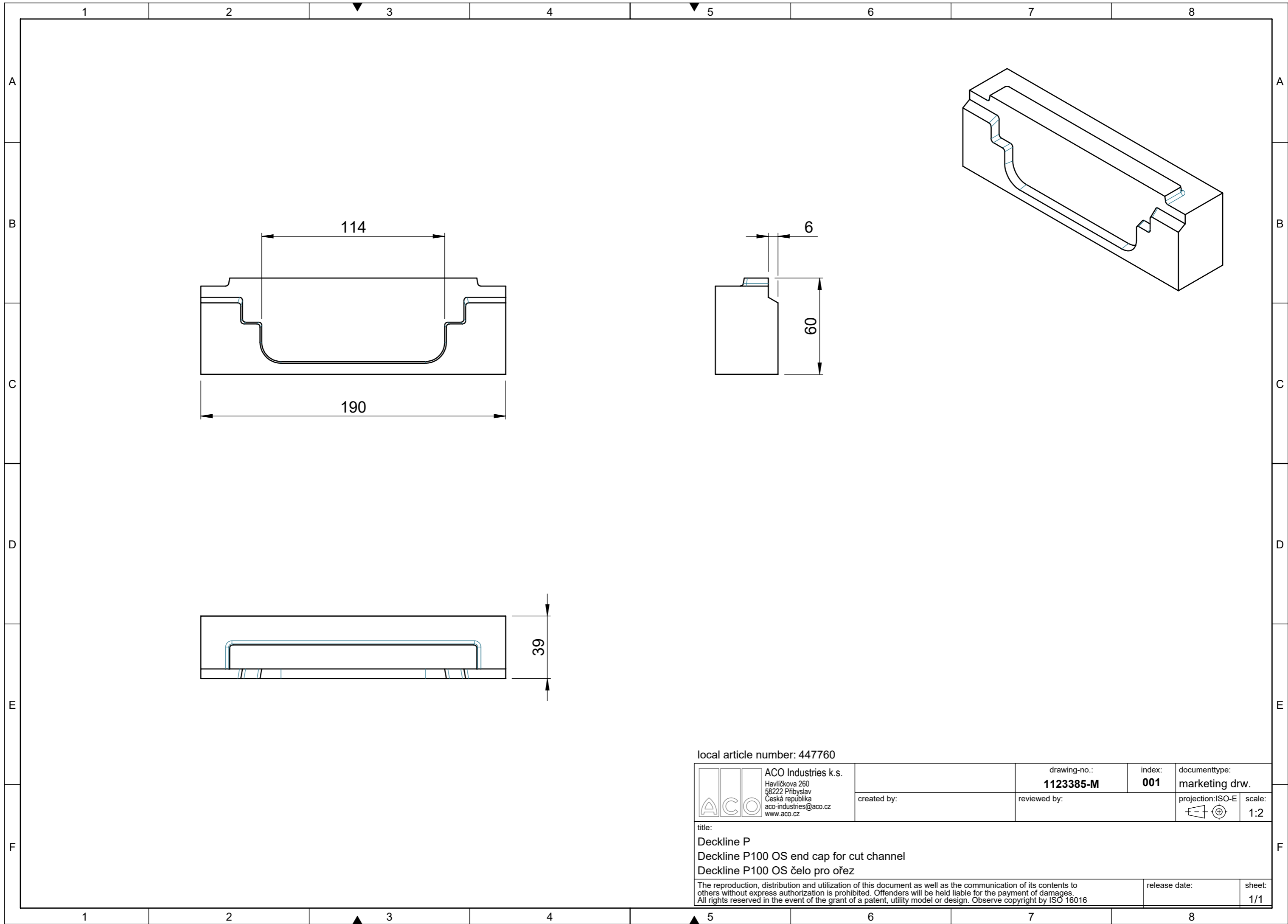

local article number: 447760

ACO ACO Industries k.s.
 Havlíčkova 260
 58222 Příbyslav
 Česká republika
 aco-industries@aco.cz
 www.aco.cz

created by:

drawing-no.:
1123385-M

index:
001

documenttype:
 marketing drw.

reviewed by:

projection: ISO-E

scale:
 1:2

title:
 Deckline P
 Deckline P100 OS end cap for cut channel
 Deckline P100 OS čelo pro ořez

The reproduction, distribution and utilization of this document as well as the communication of its contents to others without express authorization is prohibited. Offenders will be held liable for the payment of damages. All rights reserved in the event of the grant of a patent, utility model or design. Observe copyright by ISO 16016

release date:

sheet:
 1/1

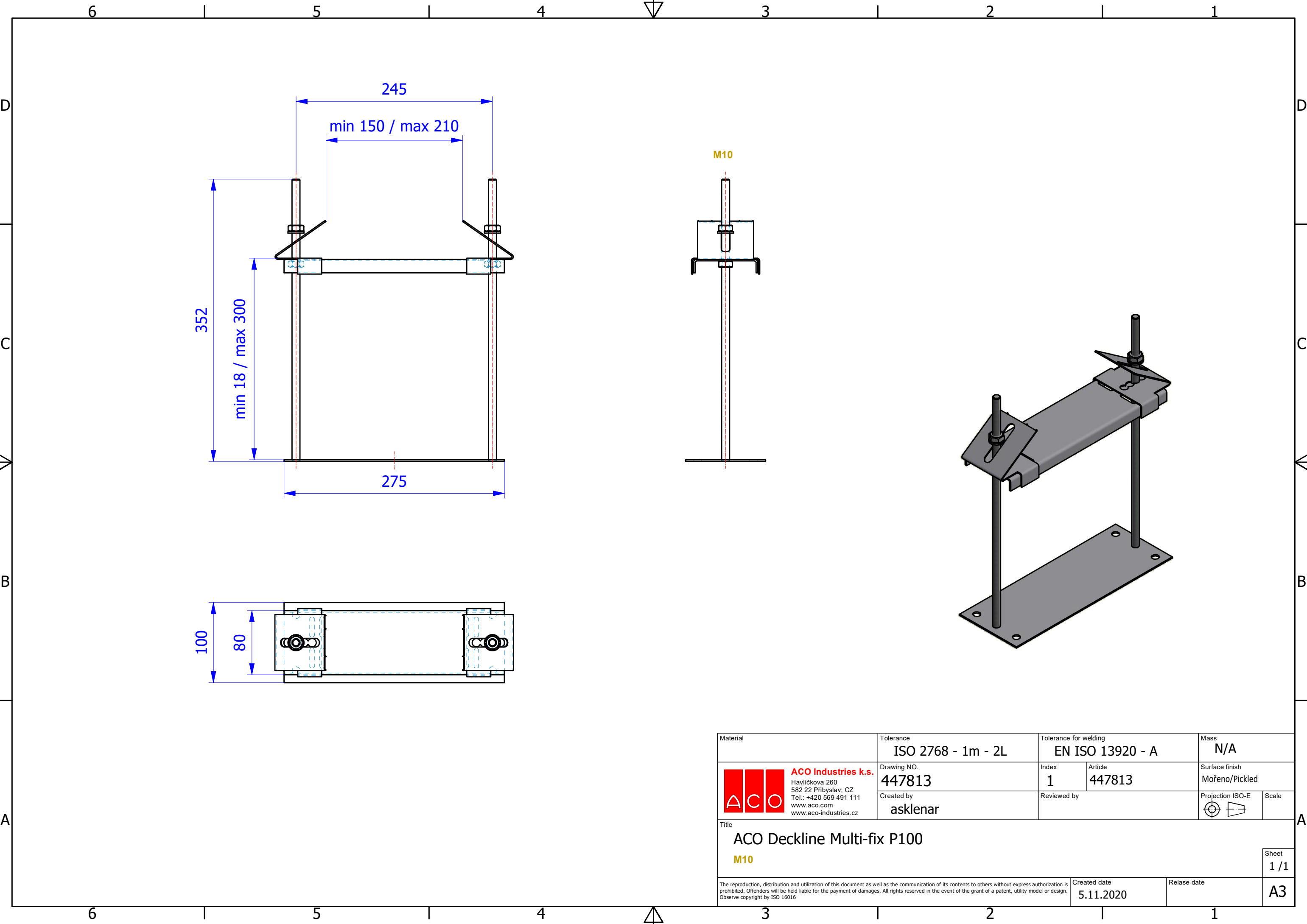

Material	Tolerance	Tolerance for welding		Mass
	ISO 2768 - 1m - 2L	EN ISO 13920 - A		N/A
 ACO Industries k.s. Havlíčkova 260 582 22 Píbyslav, CZ Tel.: +420 569 491 111 www.aco.com www.aco-industries.cz	Drawing NO.	Index	Article	Surface finish
	447813	1	447813	Mořeno/Pickled
	Created by	Reviewed by		Projection ISO-E
	asklenar			Scale
Title				
ACO Deckline Multi-fix P100				
M10				
The reproduction, distribution and utilization of this document as well as the communication of its contents to others without express authorization is prohibited. Offenders will be held liable for the payment of damages. All rights reserved in the event of the grant of a patent, utility model or design. Observe copyright by ISO 16016			Created date	Release date
			5.11.2020	
				Sheet 1 / 1
				A3