

Lipumax G-D NS1/100 - Lipumax G-D NS4/800

Lipumax G-D FST NS 1/100

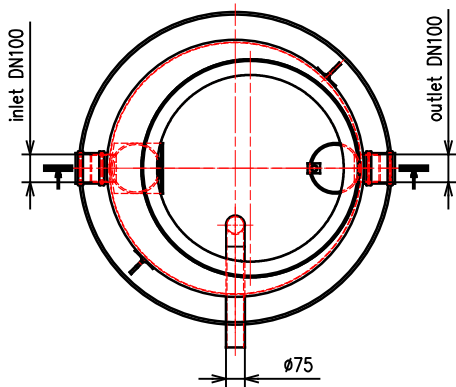
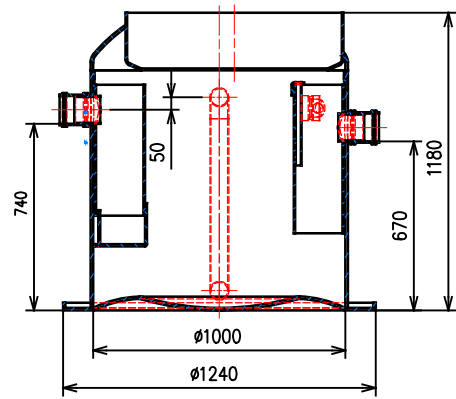

Art. 12501.05

Lipumax G-D FST NS 1-2/200

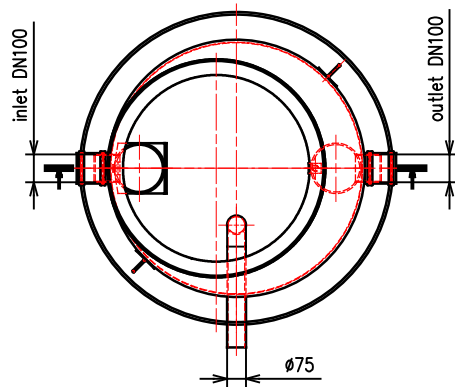
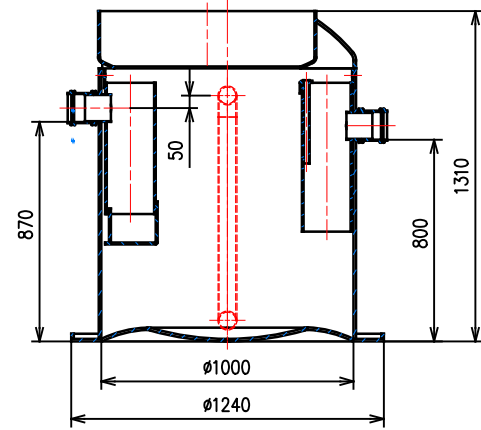

Art. 12502.05

Lipumax G-D FST NS 2/400

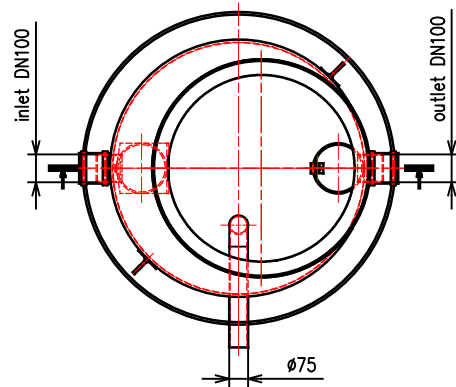
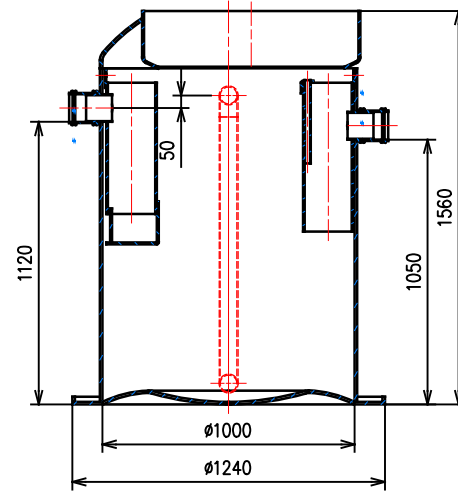

Art. 12509.05

Lipumax G-D FPI NS 4/400

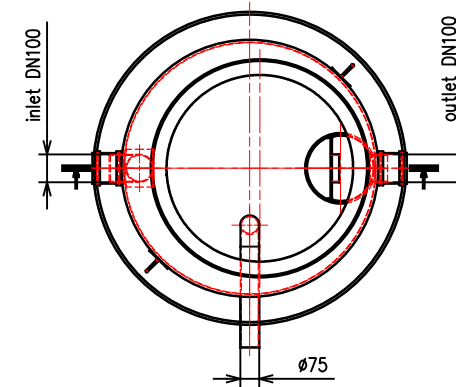
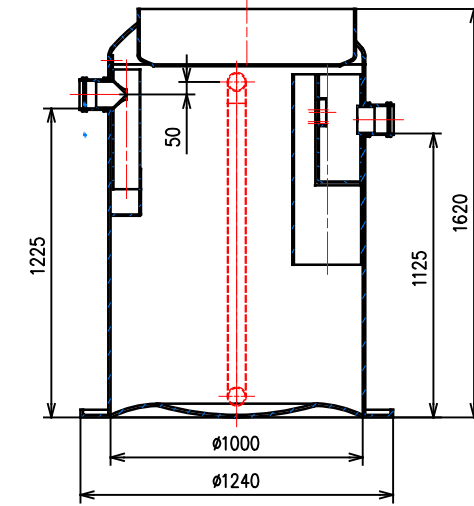

Art. 12503.15

Lipumax G-D FPI NS 4/800

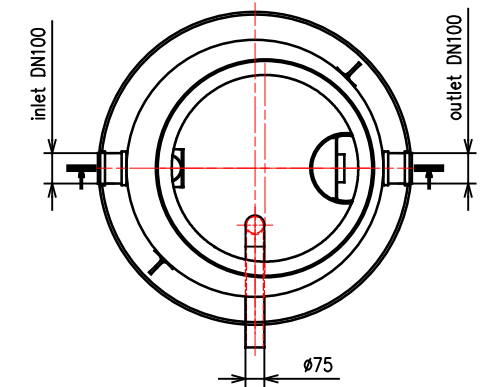
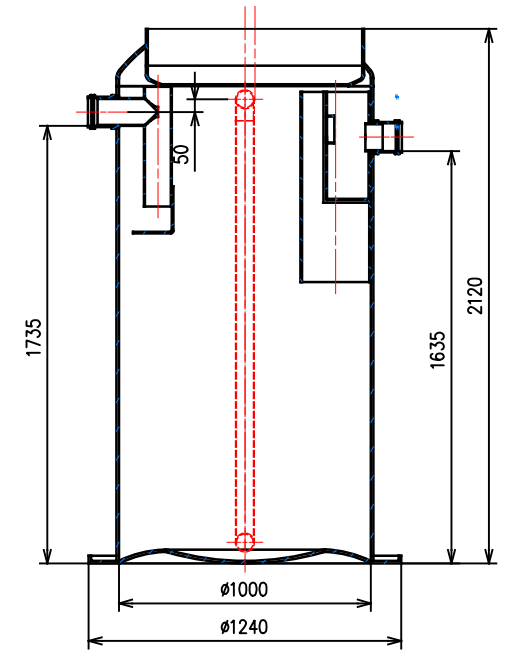

Art. 12510.15

Werkstoff: GRP (inner parts PE-HD) zul. Abweich.		Gewicht	ACO Industries Tábor s.r.o. Průmyslová 1158 391 02 Sezimovo Ústí Tel: 381474000 Fax: 381632550	
Datum		Oberfläche	ACO	
Gezeichnet	30.9.2019	Massstab	1:15	Projekt: ISO-E
Geprüft		Diese Zeichnung darf weder kopiert noch in ihrer Integrität, insbesondere zum Zweck anderweitiger Benutzung, abgedruckt werden und bleibt unser Eigentum. Schutzvermerk nach DIN 91 beachten.		
Update		Zeichnung Nr.		
LIPUMAX G - B		Index		
OVERVIEW		Ersatz für Ersatz durch		
		List: 1 / 1		

Lipumax G-D NS7/700 - Lipumax G-D NS10/2000

Lipumax G-D FPI NS 7/700

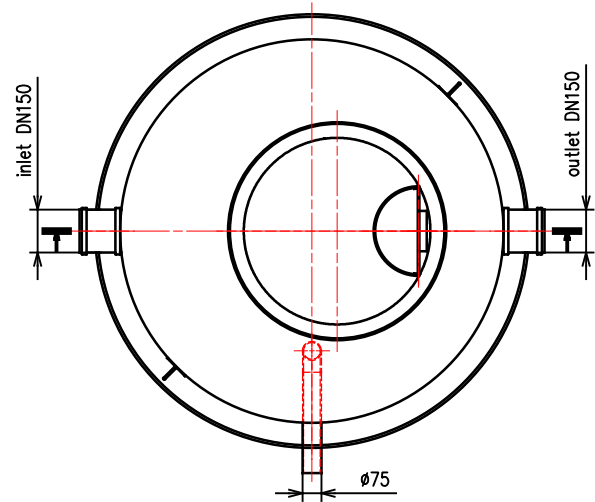
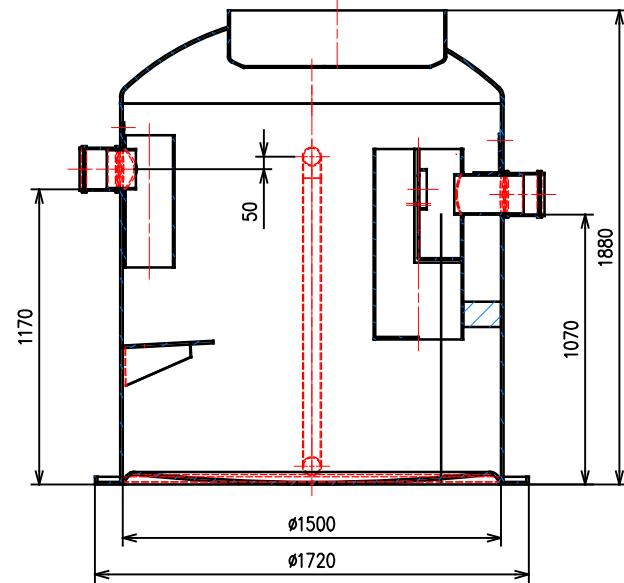

Art. 12504.15

Lipumax G-D FPI NS 7/1400

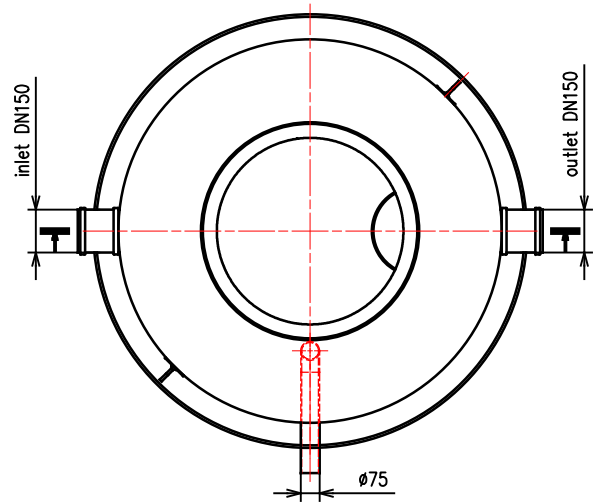
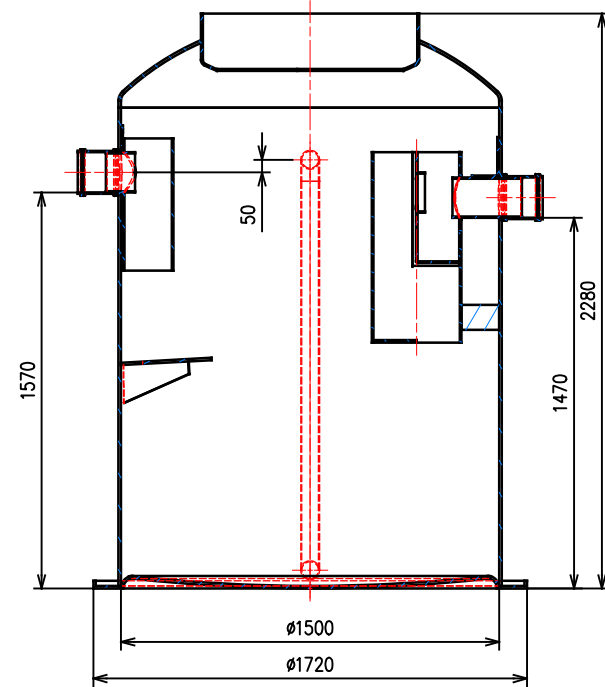

Art. 12511.15

Lipumax G-D FPI NS 10/1000

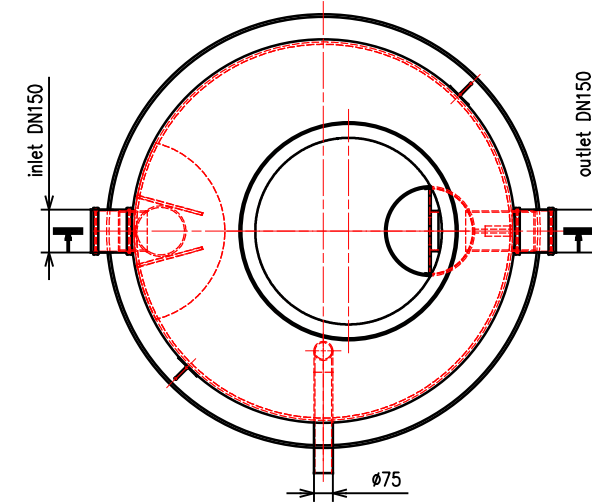
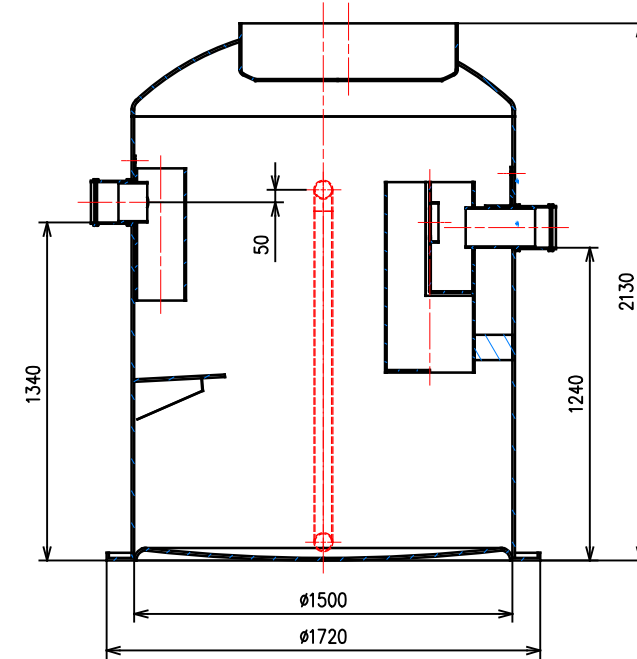

Art. 12505.15

Lipumax G-D FPI NS 10/2000

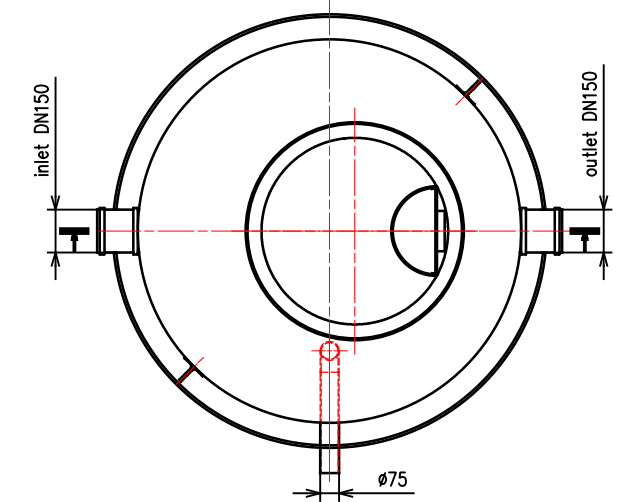
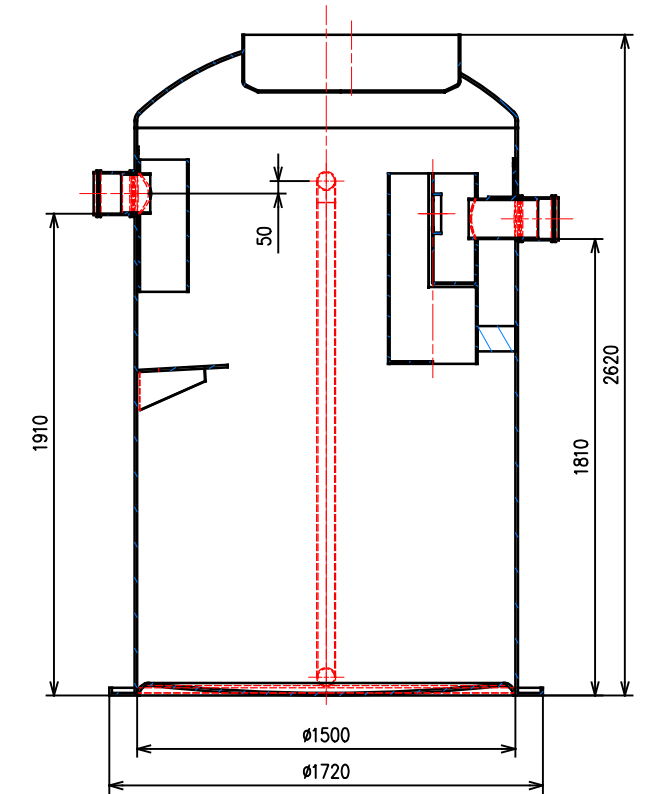

Art. 12512.15

Werkstoff: GRP (inner parts PE-HD) zul. Abweich.		Gewicht	ACO Industries Tábor s.r.o. Průmyslová 1158 391 02 Sezimovo Ústí Tel: 381474000 Fax: 381632550	
Datum: 30.9.2019		Oberfläche		ACO
Gezeichnet	Name	Massstab: 1:15	Massseinheit	Projektion: ISO-E
Geprüft		Diese Zeichnung darf weder kopiert noch abgeändert werden, insbesondere zum Zweck anderweitiger Benutzung ohne schriftliche Genehmigung des Eigentümers. Schutzvermerk nach DIN 91 beachten.		
Update		Zeichnung Nr. LIPUMAX G - B		Index
OVERVIEW		Ersatz für		List: 1/1

Lipumax G-D NS15/1500 - Lipumax G-D NS20/2000

Lipumax G-D FST NS 15/1500

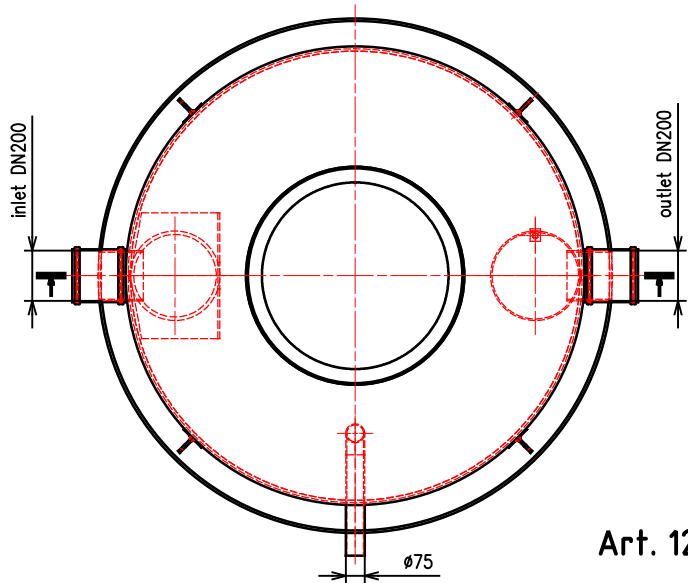
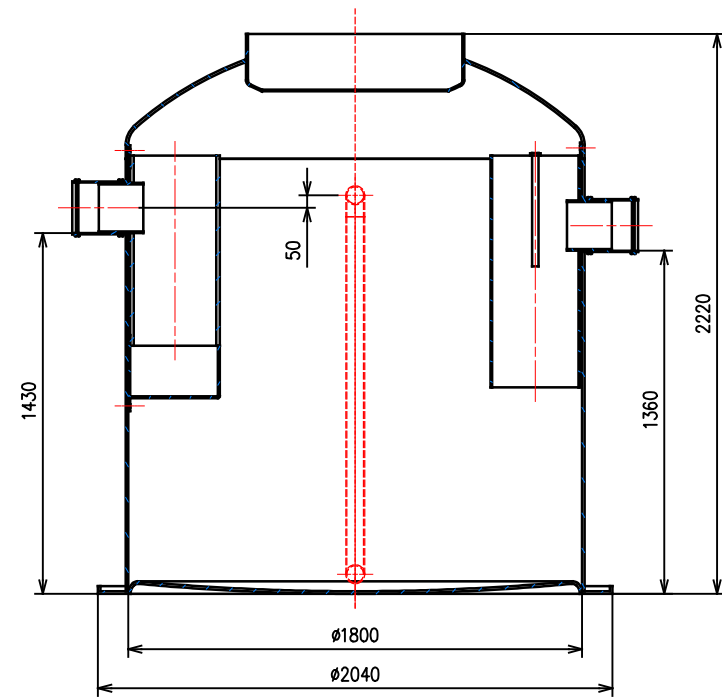

Art. 12515.05

Lipumax G-D FST NS 15/3000

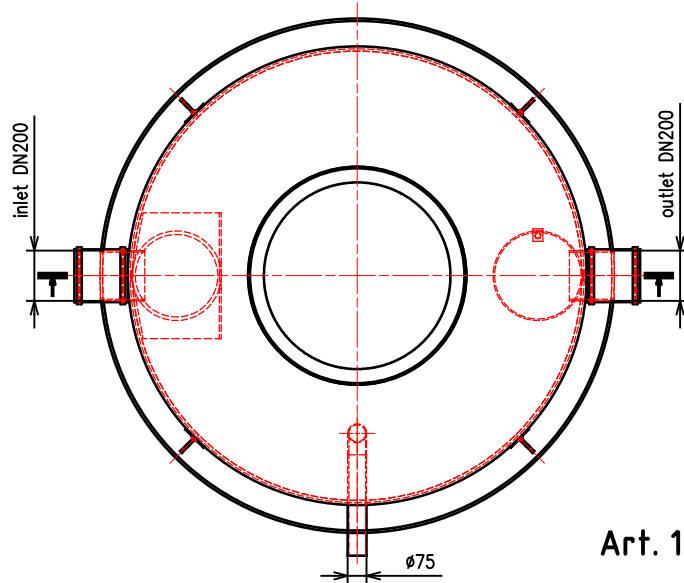
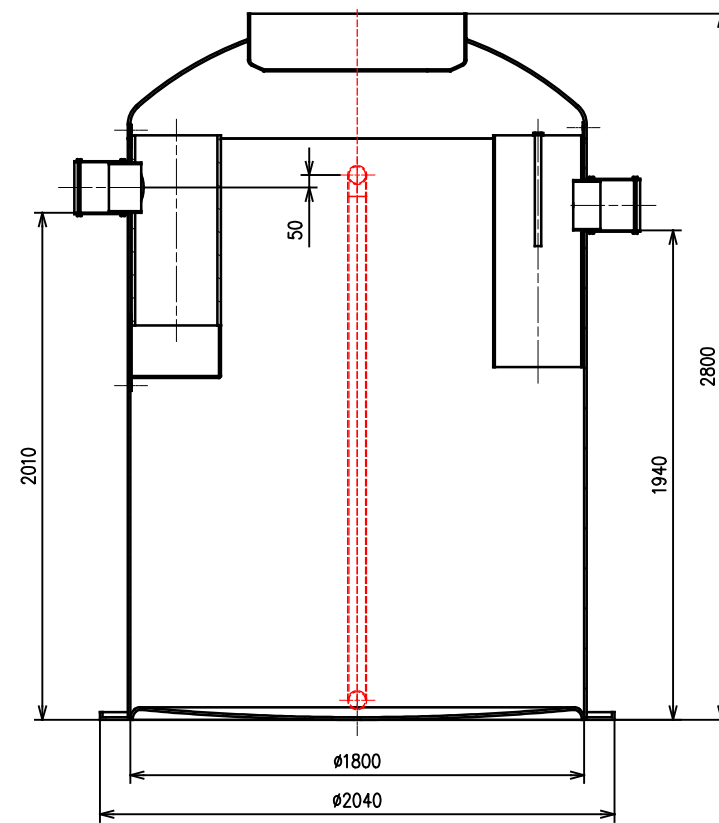

Art. 12513.05

Lipumax G-D FST NS 20/2000

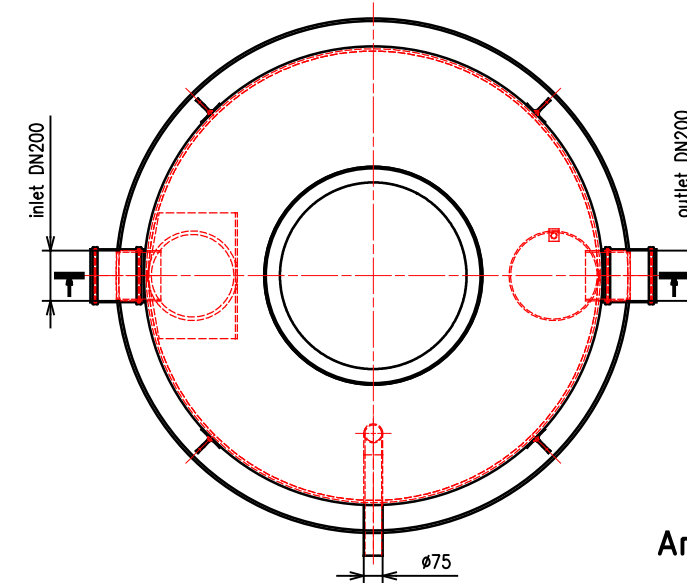
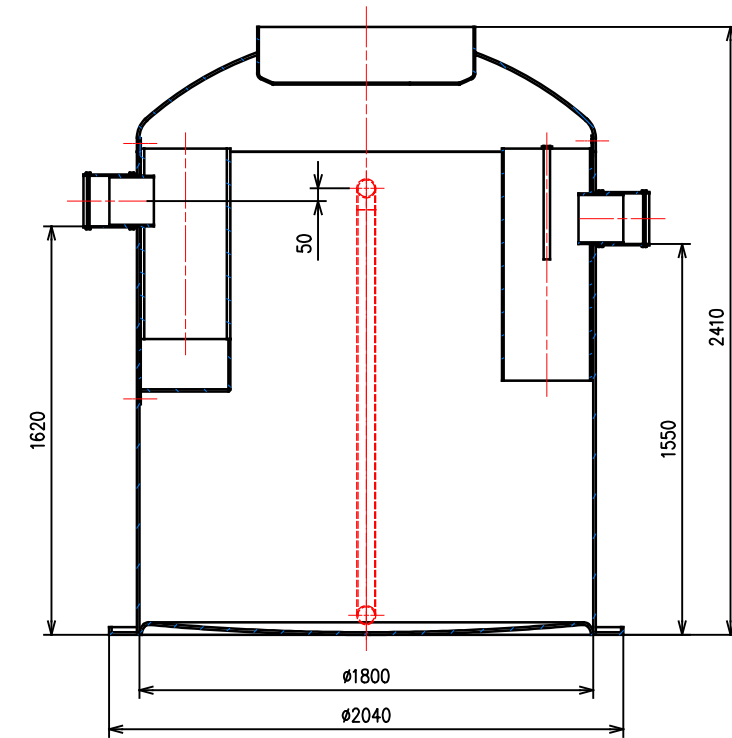

Art. 12517.05

Werkstoff: GRP (inner parts PE-HD) zul. Abweich.		Gewicht	ACO Industries Tábor s.r.o. Průmyslová 1158 391 02 Sezimovo Ústí Tel: 381474000 Fax: 381632550	
Datum		Name		Projektion: 1SO-E
Gezeichnet	30.9.2019			<p>Diese Zeichnung darf weder kopiert noch abgeändert werden. Insbesondere zum Zweck anderweitiger Benutzung abgedruckt werden und bleibt unser Eigentum. Schutzvermerk nach DIN 91 beachten</p>
Gepüft		Massstab	1:15	
Update		Masseneinheit		
LIPUMAX G - B			Zeichnung Nr.	Index
OVERVIEW			Ersatz für	Index
			Ersatz durch	List:1 / 1

Lipumax G-D NS20/4000 - Lipumax G-D NS25/5000

Lipumax G-D FST NS 20/4000

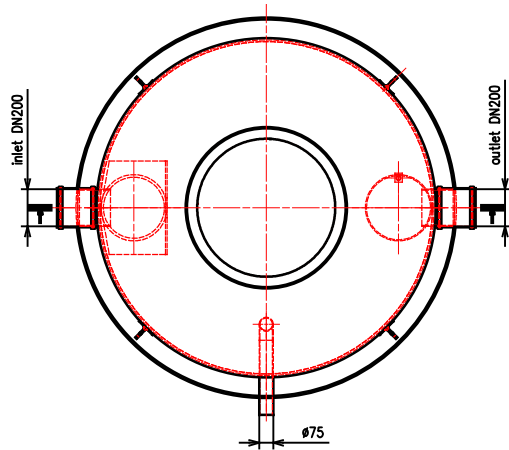
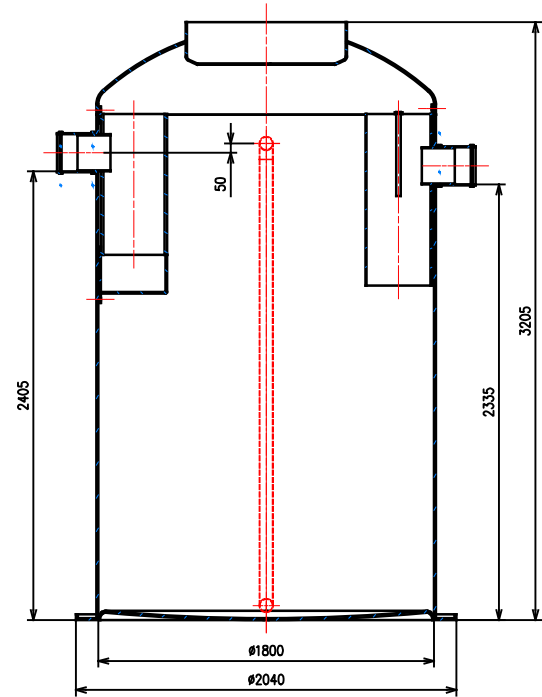

Art. 12516.05

Lipumax G-D FST NS 25/2500

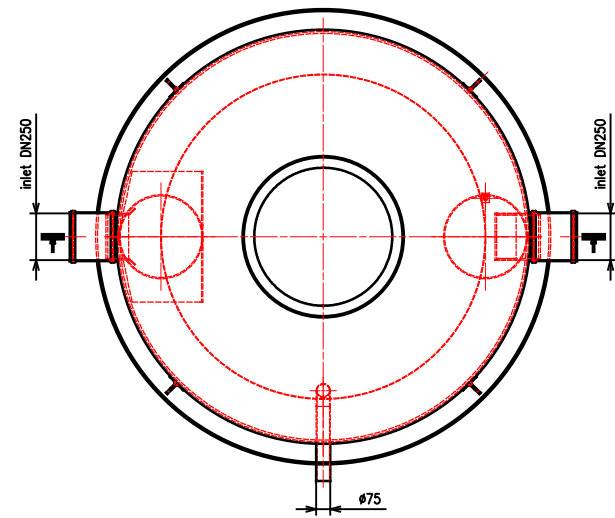
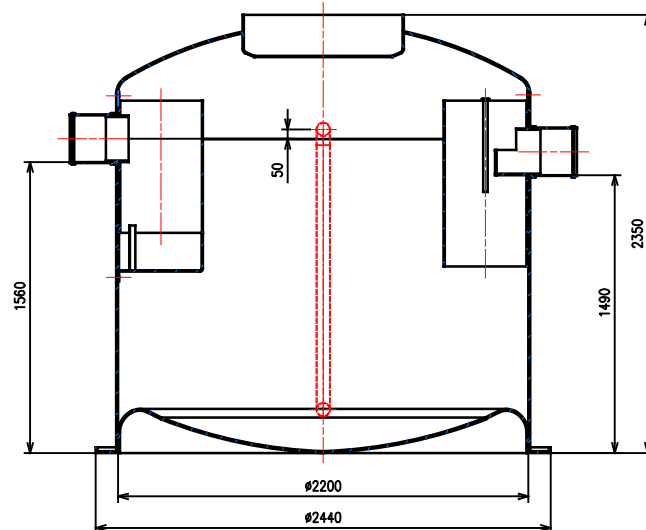

Art. 12518.05

Lipumax G-D FST NS 25/5000

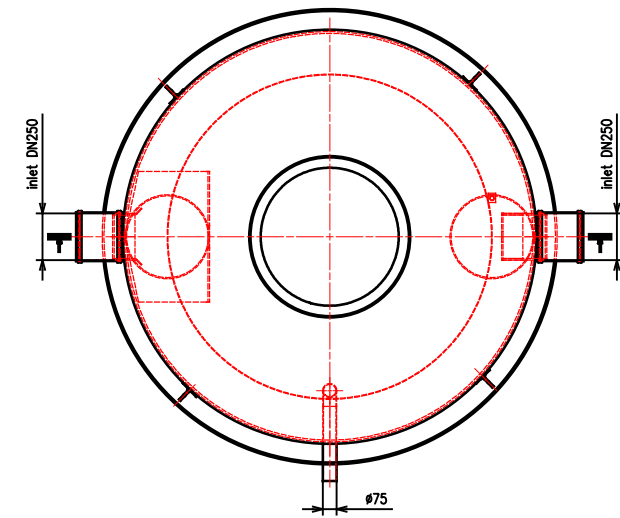
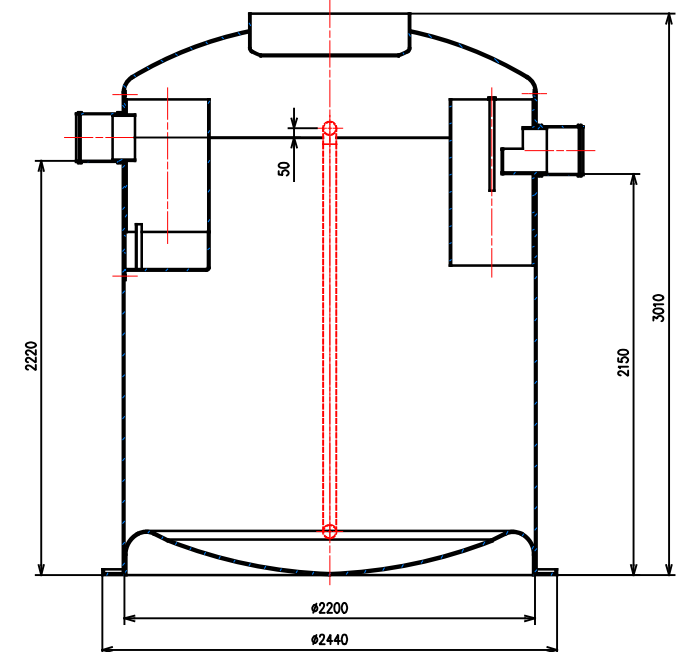

Art. 12514.05

Werkstoff: GRP (inner parts PE-HD) zul. Abweich.		Gewicht	ACO Industries Tábor s.r.o. Průmyslová 1158 391 02 Sezimovo Ústí Tel: 381474000 Fax: 381632550	
Gezeichnet: 30.9.2019		Oberfläche	ACO	
Geprüft		Massstab: 1:15	Projekt: ISO-E	
Update		Masseneinheit	Diese Zeichnung darf weder kopiert noch abgeändert werden, insbesondere zum Zweck der endgültigen Bemessung. Jegliche Änderungen sind dem ursprünglichen Zeichner zu melden.	
LIPUMAX G - B		Zeichnung Nr.: GRP-0321-00-00	Index	
OVERVIEW		Ersatz für	List: 1 / 1	
		Ersatz durch	A1	